

Item:

MSB-100/150/200W-50K

MSB-200/240/300W-50K

MSB-100/150/200W-50K-SB

MSB-200/240/300W-50K-SB

## Wattage Selectable LED Shoebox Light

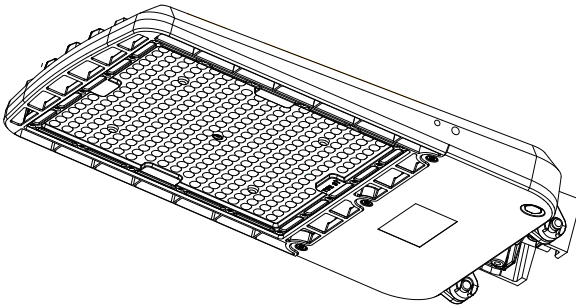

# Wattage Selectable LED Shoebox Light

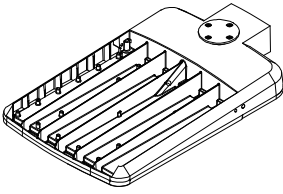

WITH OUT PHOTOCELL BASE VERSION

Item:  
MSB-100/150/200W-50K  
MSB-200/240/300W-50K

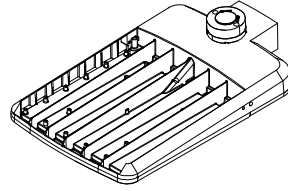

WITH PHOTOCELL BASE VERSION

Item:  
MSB-100/150/200W-50K-SB  
MSB-200/240/300W-50K-SB

## Safety Instruction

### ⚠ Cautions:

1. Can not use the electric generator to test the LED lamp.
2. Please abide by related country, regional and local law and regulations when install this fixture.
3. To avoid electrical shock and damage, please do not install the lights in raining days.

### ⚠ Notices:

1. To prevent from electric shock or fire risk, the installation must be conducted by operator who have professional electrical knowledge.
2. Please wear gloves to avoid injury before installing lamps.
3. During or after installation, if there are situations such as smoke, fire in the wires or lamps, please turn off the power immediately and notify relevant personnel of an overhaul.
4. This light can be used for outdoor installation.

### ⚠ Instructions:

1. This product has dimming and non-dimming function, which differs in installation ways.
2. 3 kind of dimming functions are available in this shoebox light:
  - 1) Constant current can be achieved by 0-10V dimming.
  - 2) PWM signal dimming.
  - 3) Variation of resistance unit dimming(Please choose the appropriate dimming way according to your needs. You can also choose not to use this function)
3. Choose the wire connection ways, dimming ways and installation ways according to your needs and the LED fixture purchased.

# Tools Required



NOTE: Keep your receipt and these instructions for Proof of Purchase.



Ladder

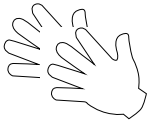

Gloves

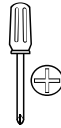

Phillips Screwdriver



Wire Stripper

# Wiring Diagram:

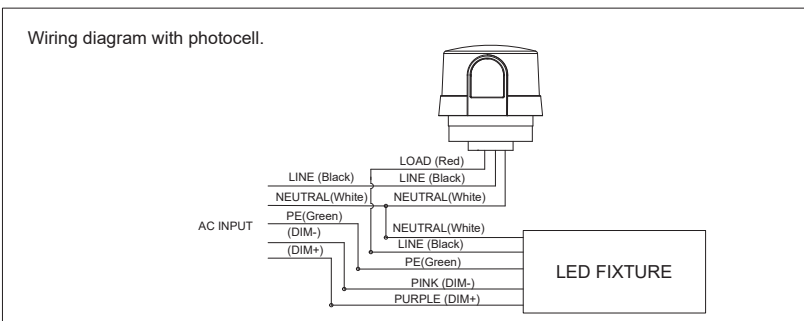
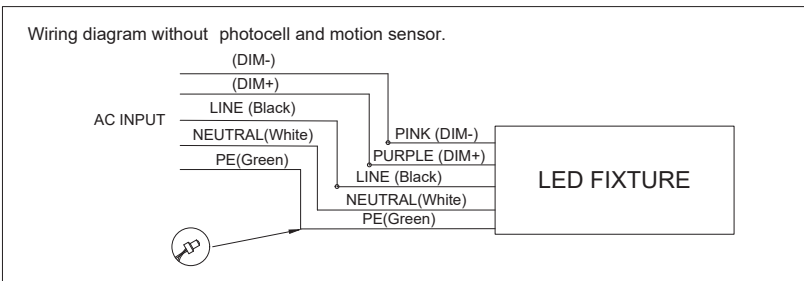
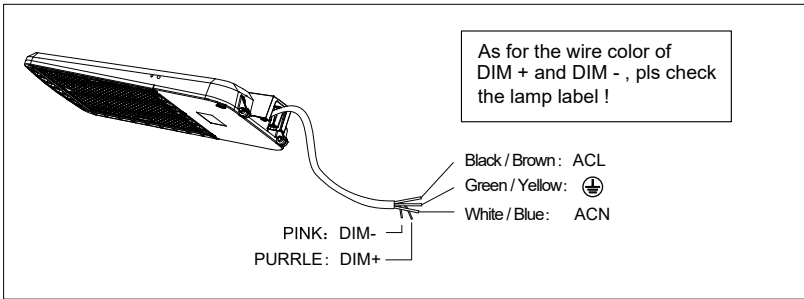

# Wiring Diagram:

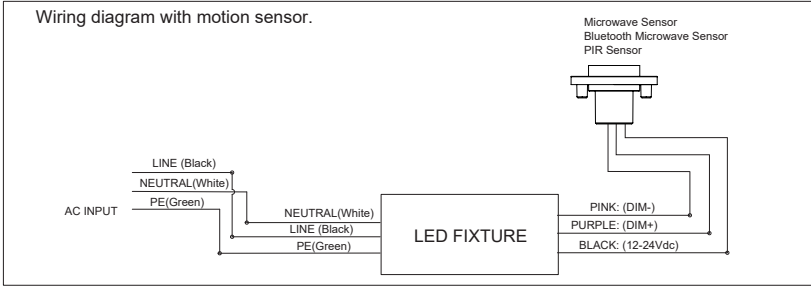

# Optional Fittings

## Optional Brackets (Sold Separately) and Installation Instructions

There are optional brackets for this fixture.

The following is shoebox fixtures with different brackets.

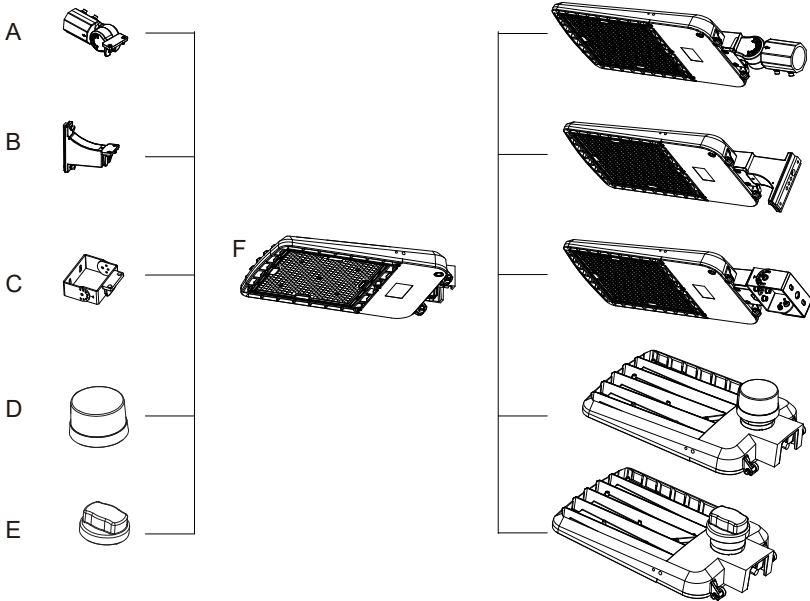

	PARTS	pcs
A	Shoebox Slip Fitter	1
B	Square / Round Pole Mount	1
C	Shoebox Trunnion Mount	1
D	Photocell	1
E	Shorting cap	1
F	Shoebox fixtures	1

# Brakets Installation Guide

Both available for w/wo photocell base version

MSB-100/150/200W-50K, MSB-200/240/300W-50K,  
MSB-100/150/200W-50K-SB, MSB-200/240/300W-50K-SB

## TYPE A-(Slip-fitter)

Step 1 : Disassemble the slip-fitter with a wrench.

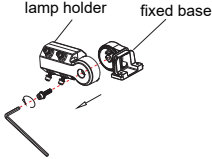

Step 2: Pass the fixture's AC input wires through the fixing base then tighten screws to assemble fixing base to fixture body.

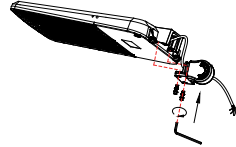

Step 3: Pass the fixture's input wires through the lamp holder and lock it.

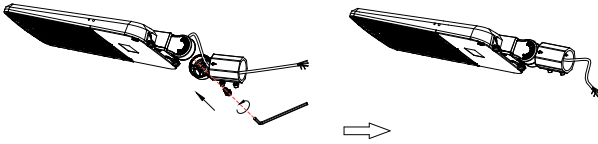

Step 4: Loosen the 4 locking bolts in the Type A bracket by a wrench.

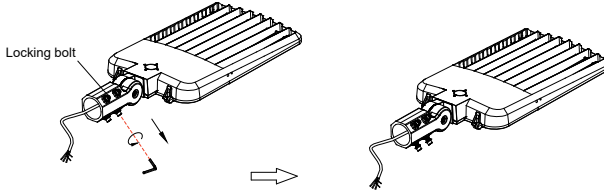

Step 5: Connect the fixture's AC input wires to pole-wires with connectors, L to L (black), N to N (White), PE to PE (Green); If need to connect dimming wires from the pole to fixture, please also use the connector to connect "Dim +" (purple) to "Dim +" (purple), "Dim -" (pink) to "Dim -" (pink).

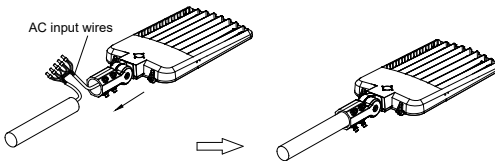

Step 6: Tighten the 4 locking bolts back.

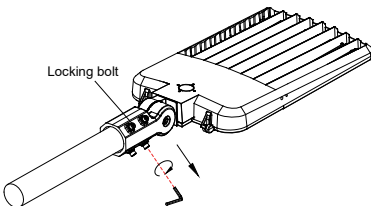

Step 7 :Loosen the locking bolt in the slip-fitter by a wrench to adjust fixture to a appropriate angle,adjustable angle range 90 then this locking bolt.

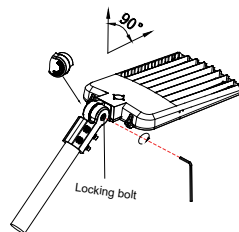

# Brackets Installation Guide

## TYPE B-(Squar/Round pole-mount)Installation

Step 1: Loosen the screws from the TYPE C bracket, open junction box cover; pass fixture's AC input wires through TYPE C bracket.

Step 2: Assemble TYPE C bracket to fixture body by tightening screws with a wrench.

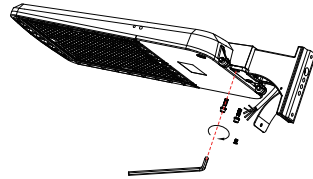
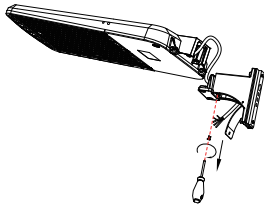

Step 3: Remove the screws with screwdriver, well set the iron bar, remove the screws to open the junction box cover, then pass fixture's AC input wires through junction box as shown figure.

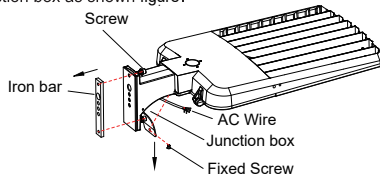

Step 4: When install to square/round pole, align the holes of Type C bracket and pole, pass the screws throughout both holes, then put iron bar into pole to attach to screws.

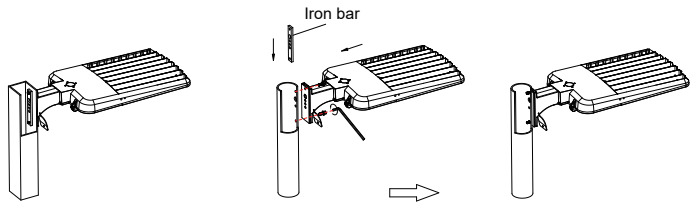
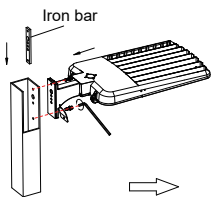

Attention: When install to round pole, please remove the rubber gasket.

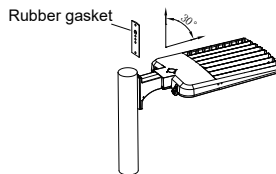

Step 5: Pass the fixture's AC input wires through the pole, pull them out together the pole-wire for connection.

Or pass the pole-wires into Type B bracket, pull them out together with fixture's AC wire from junction box, connect the fixture's AC input wires to pole-wires with connectors, L to L (black), N to N (White), PE to PE (Green)

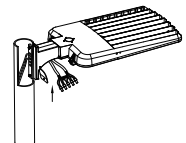
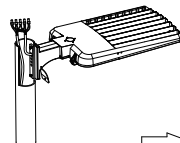
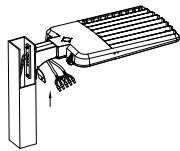
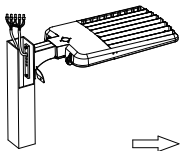

# Brackets Installation Guide

Step 6. 1: Push the connected wires into the pole, close the pole's top cover, then close the junction box cover by tightening the screws.

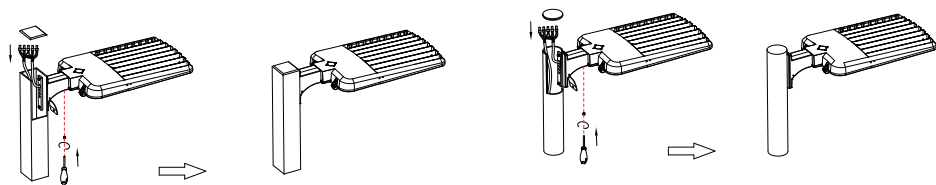

Step 6. 2: Push the connected wires into bracket junction box, close the box cover by tightening the fixing screws, then close the pole's top cover.

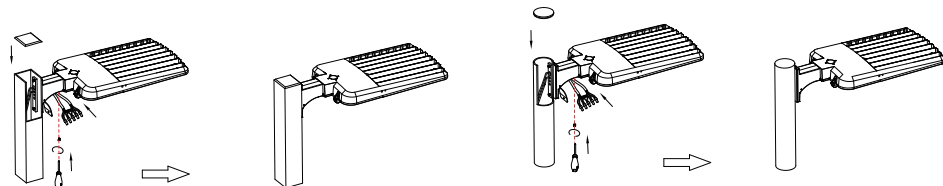

## TYPE C-(Trunnion)

Step 1 : Mark the fixing holes locations on the wall with Type D bracket, then drill the hole in 10mm diameter with an electric drill;

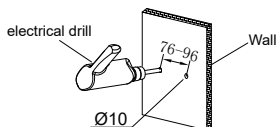

Step 2 : Knock the two expansion bolts into wall with a hammer

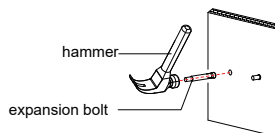

Step 3: Fix the TYPE D bracket on the mounting-surface by tightening screws with a wrench.

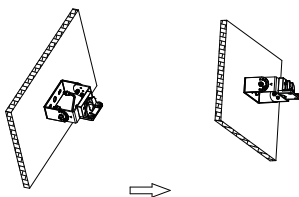

Step 4: Pass the fixture's AC input wires through the Type D bracket; then hang the fixture into the TYPE D bracket, tighten screws to lock it to Type D bracket with a wrench.

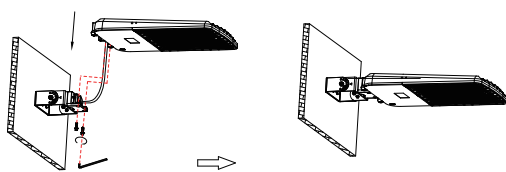

Step 5: Loosen the angle adjustable screws on both sides of Type D bracket, rotate fixture to an appropriate angle required and tighten the two screws, see fig.31; then connect the fixture's

Note: The adjustable angel range is 0-90 °. As shown in Fig 32

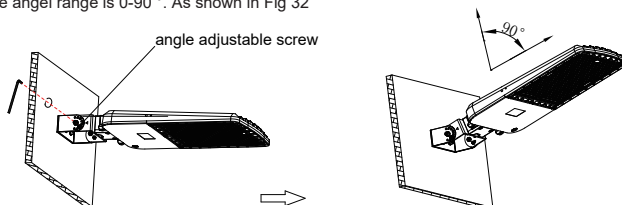

# Shorting Cap And Photocell Installation Guide

Available for with photocell base version

MSB-100/150/200W-50K-SB

MSB-200/240/300W-50K-SB

## How to install shorting cap

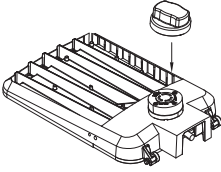

1. Insert shorting cap into (2) curved slots on lamp top.

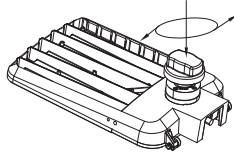

2. Twist unit clockwise to lock into place.

## How to install photocell

1. Remove the shorting cap.

2. Insert blue Dusk to Dawn sensor into (3) curved slots on lamp top.

3. Twist unit clockwise to lock into place.

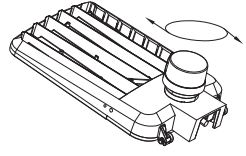
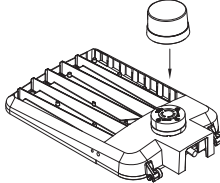
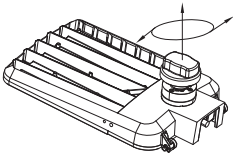

## Field-adjustable Wattage

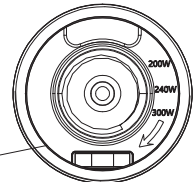
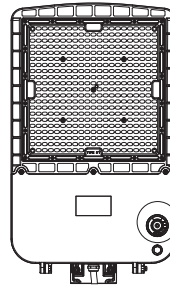
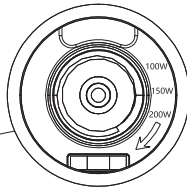
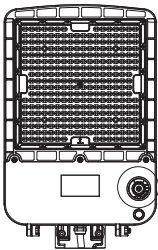

Factory Settings:

Model	Wattage
MSB-100/150/200W-50K	200W
MSB-200/240/300W-50K	300W
MSB-100/150/200W-50K-SB	200W
MSB-200/240/300W-50K-SB	300W

1. Open the cover of the power DIP switch respectively.
2. Toggle the DIP switch to the corresponding gear as indicated by the laser engraving arrow to achieve the required power conversion.

## WARRANTY

This product is warranted for 5 years from the date of purchase. If this product does not perform to the specifications supplied on this package, send an email to us for product return and replacement. This replacement is the sole remedy available. Liability for incidental or consequential damage is expressly excluded.