

27.94 cm / 11 inch

21.59 cm 8.5 inch

CARE AND MAINTENANCE

Clean with non-abrasive glass cleaner and soft cloth. Do NOT use cleaner contains abrasive agents.
 - Turned off the power before attempt to maintain the luminaire.
 - Liquid spray should be applied to the cleaning cloth, do NOT sprayed liquid directly onto the fixture.

TROUBLESHOOTING

Fixture does not light.

Possible Solution and Corrective Action:
 1, Power is off - Check fuse, circuit breaker and switch.
 2, Incorrect wire connection - Check wiring.

Circuit breaker trips when turned on.

Possible Solution and Corrective Action:
 1, Incorrect wire connection - Check wiring.

Flickering when turned on.

Possible Solution and Corrective Action:
 1, Dimmer not compatible - This product is not compatible with dimmers, do not use with dimmers.
 2, Loose wiring - Check wiring.
 3, Faulty switch - Check switch.

WARRANTY

We warrants this products to be free from defects in material and workmanship for up to five (5) years from the date of purchase at its sole discretion. Any changes or modifications and applications not expressly approved by the manufacturer could void the user's authority to operate the equipment and warranty. Please contact for more warranty informations.

SURFACE MOUNT DOWNLIGHT FIXTURE WITH MOTION SENSOR

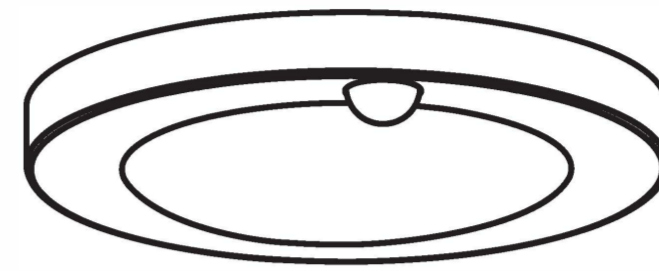

PACKAGE CONTENTS

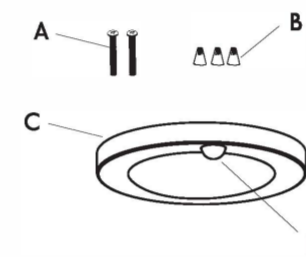

	PARTS	QT
A	Screws	2
B	Wiring nuts	3
C	downlight	1
D	built-in motion sensor	1



4

1

SAFETY INSTRUCTION

Please read and understand all instructions before operate or install the product. Failure to do so may lead to electric shock, fire or other injuries that could be hazardous or even fatal.
 - Shut off the electricity to the wires that you are working on.
 - Do NOT open, no user serviceable parts inside. Any changes or modifications and applications not expressly approved by the manufacturer could void the user's authority to operate the equipment and warranty.

WARNING

- Risk of fire or electric shock.
- LED retrofit kit installation requires knowledge of luminaires electrical systems. Do NOT attempt installation if not qualified. Contact a qualified electrician.
- Install this kit only in the luminaires that have the construction features and dimensions shown in the photographs and/or drawings.
- Do NOT exceed the input rating of the luminaire.
- Do NOT make or alter any open holes in an enclosure of wiring or electrical components during installation.
- To prevent wiring damage or abrasion, do NOT expose wiring to edges of sheet metal or other sharp objects.
- This device is not intended for use with emergency exits.
- This luminaire has been modified to operate LED lamp. Do NOT attempt to install or operate incandescent lamps or CFL in this luminaire.
- Suitable for TYPE IC or TYPE NON-IC luminaires.
- This retrofit kit is accepted as a component of a luminaire where the suitability of the combination shall be determined by authorities having jurisdiction.

CAUTION

- Connect fixture to a 120 Volt, 60Hz power source only. Any other connection void the warranty.

This device complies with Part 15 of the FCC Rules. Operation is subject to the following two conditions: (1) This device may not cause harmful interference, and (2) this device must accept any interference received, including interference that may cause undesired operation.
 This equipment has been tested and found to comply with the limits for a Class B digital device, pursuant to part 15 of the FCC Rules. These limits are designed to provide reasonable protection against harmful interference in a residential installation. This equipment generates, uses and can radiate radio frequency energy and, if not installed and used in accordance with the instructions, may cause harmful interference to radio or television reception, which can be determined by turning the equipment off and on. The user is encouraged to try to correct the interference by one or more of the following measures:

- Reorient or relocate the receiving antenna.
- Increase the separation between the equipment and the receiver.
- Connect the equipment into an outlet on a circuit different from that to which the receiver is connected.
- Consult the dealer or an experienced radio/TV technician for help.

2

SURFACE MOUNT INSTALLATION

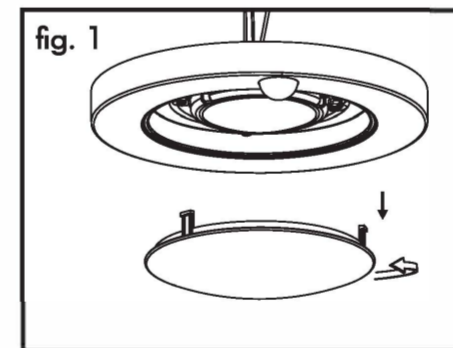

1. To prepare the disk light for installation:
 - Make sure the power is off.
 - Hold the trim firmly, remove the diffuser with hands by turning the diffuser counter clockwise.

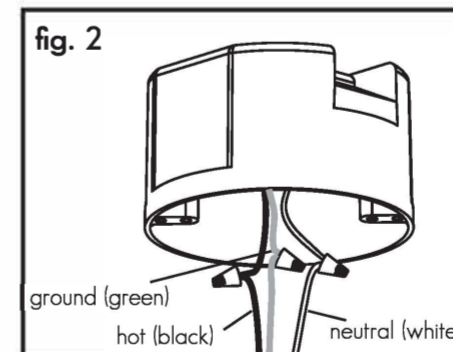

2. The junction box three wires: hot (black), neutral (white) and bare ground (green). Connect the hot wires from the back of the disk light and the other from the junction box together with wiring nut. Repeat the step with the two neutral wires and two bare ground wires.

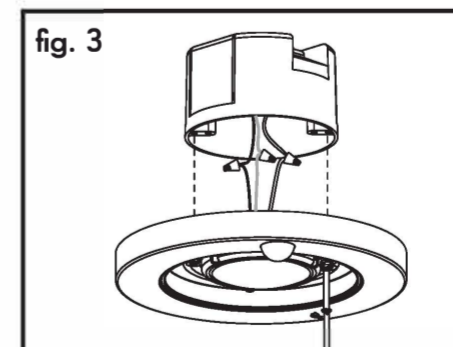

3. Push all the wires and cables into the junction box. Use a philip head screwdriver to mount the disk light to the junction box.

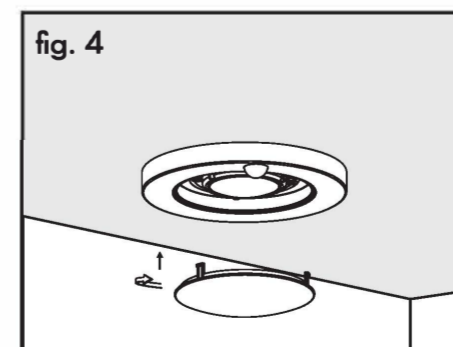

4. Put the diffuser back to the disk light. Lock the diffuser by turning it clockwise with hands. Make sure the diffuser is secured to complete the installation.

3